

Article

## A New Battery Energy Storage Charging/Discharging Scheme for Wind Power Producers in Real-Time Markets

Minh Y Nguyen, Dinh Hung Nguyen and Yong Tae Yoon \*

Seoul National University, Gwanak-ro 599, Gwanak-gu, Seoul 151-744, Korea;

E-Mails: minhy@snu.ac.kr (M.Y.N.); hunghtd@snu.ac.kr (D.H.N)

\* Author to whom correspondence should be addressed; E-Mail: ytyoon@ee.snu.ac.kr;  
Tel./Fax: +82-02-880-9144.

Received: 12 September 2012; in revised form: 2 November 2012 / Accepted: 7 December 2012 /

Published: 19 December 2012

---

**Abstract:** Under a deregulated environment, wind power producers are subject to many regulation costs due to the intermittence of natural resources and the accuracy limits of existing prediction tools. This paper addresses the operation (charging/discharging) problem of battery energy storage installed in a wind generation system in order to improve the value of wind power in the real-time market. Depending on the prediction of market prices and the probabilistic information of wind generation, wind power producers can schedule the battery energy storage for the next day in order to maximize the profit. In addition, by taking into account the expenses of using batteries, the proposed charging/discharging scheme is able to avoid the detrimental operation of battery energy storage which can lead to a significant reduction of battery lifetime, *i.e.*, uneconomical operation. The problem is formulated in a dynamic programming framework and solved by a dynamic programming backward algorithm. The proposed scheme is then applied to the study cases, and the results of simulation show its effectiveness.

**Keywords:** real-time market; real-time price; deregulated market; wind power; battery energy storage; charging/discharging scheme

### Nomenclature:

K	The time index of day-ahead market (1 hour)
k	The time index of real-time market (5 minutes)
$\lambda_K^{DA}$	Day-ahead price, [\$/MWh]

$\lambda_k^{RE}$	Regulation price, [\$/MWh]
$\lambda_k^{RT}$	Real-time price, [\$/MWh]
$\bar{P}[K]$	Hourly prediction of wind generation, [MW]
$p_w[k]$	Real-time variation of wind generation, [MW]
$p^{RT}[k]$	Real-time dispatch of WPP, [MW]
$P_b[k]$	Real-time charging/discharging of BES, [MW]
$SoC_{max}$	Maximum state of charge of BES, [MWh]
$SoC_{min}$	Minimum state of charge of BES, [MWh]
$RoD_{max}$	Maximum rate of discharge of BES, [MW]
$C_{rep}$	Replacement cost of battery of BES, [\\$]
$Q_{lifetime}$	Lifetime-throughput of BES, [Ah]
$SoC_s$	Starting state of charge of BES, [MWh]
$SoC_e$	Ending state of charge of BES, [MWh]
$N$	Number of battery in the bank
$\eta_c$	Charging efficiency of BES
$\eta_d$	Discharging efficiency of BES
$\eta_{rt}$	Roundtrip efficiency of BES ( $\eta_{rt} = \eta_c \times \eta_d$ )
$c^{bw}$	Battery wear cost of BES
$f_{SoC}$	Impact of SoC on the lifetime
$f(I,n)$	Impact of current on the lifetime
$c_{SoC, min}$	Coefficient of lowest SoC in the lifetime
$c_{ll}$	Cost of lifetime losses of BES, [\$/Ah]
$\Pi$	Profit of WPP, [\\$]
$x_k$	State variable in DP framework
$u_k$	Control variable in DP framework
$w_k$	Random variable in DP framework
$g_k(x_k, u_k, w_k)$	Cost function in DP framework
$f_k(x_k, u_k, w_k)$	State transition function in DP framework
$J_k(x_k)$	Cost-to-go function in DP framework
$x_0$	Initial state
$x_e$	Ending state

## 1. Introduction

The increases in fossil fuel prices and environmental concerns have led to a boost in installed wind energy capacity in the last decade. In this trend, wind power and other renewable energy sources (RES) are encouraged by many regulatory policies such as the renewable standard in the U.S., the renewable obligation in UK, and the feed-in tariff in Nordic countries. However, these supporting policies have been redesigned since the recent deregulation of electric power industry which tends to put wind power into the market forces [1]. As a consequence, besides receiving a general subsidy,

wind power producers (WPPs) need to compete for generation and on the other hand, being responsible for the problems, if any, they cause in the electric power network. The matter of fact is that the intermittence of natural resources (*i.e.*, wind speed) makes the prediction of wind generation at high uncertainty, even with modern prediction tools (10%–15%), compared to 1%–2% error of load forecasting. In addition, the power output of wind generators fluctuates continuously as time. These issues significantly decrease the competitiveness of WPPs in comparison with the conventional sources: coal-fired, gas-fired and hydro power plants [2].

In order to improve the value of wind power in such deregulated environment, a number of study efforts have been paid; most of them focus on the scenario of Nordpool, *i.e.*, the power pool in Scandinavia Peninsula including Denmark, Sweden, Finland and Norway. This area is characterized by the high share of wind power in total energy consumption and being considered as future power system of many countries. In Nordpool, the regulation cost (called imbalance penalty in some references) faced by WPPs is calculated as product of the power imbalance and the regulation price; in which the power imbalance refers to the deviation of actual power generation from what is bided ahead of time. Those previous studies can be categorized into three groups: (1) market approach, (2) bidding approach, and (3) battery approach.

Firstly, the market approach proposes an intra-day market (or after-sale market) which has a smaller gate closure, meaning the time period between the market closure and the physical delivery of electricity is shorter (than the typical 12–36 hour ahead of spot market). In this market, WPPs with better prediction can submit bids to correct the error of the submitted bids in the spot market. By thus, the overall regulation cost can be decreased [3,4]. However, the practice of this market (Elbas) shows that it is not very active and only a small amount of energy is traded here [5].

Secondly, the bidding approach attempts to optimize the bidding strategy of WPPs in the spot market [5–9]. This strategy takes into account both the asymmetry of regulation prices (up and down regulation) and the availability of the probabilistic error of prediction tools. Then, instead of bidding the average value, the optimal strategy tends to lead WPPs bidding at a lower amount in order to avoid the expensiveness of up regulation. This will result in a reduction of overall regulation cost. The main drawback of this approach is that the credible probabilistic model of prediction error is not always achievable that requires such a long time data [6].

Thirdly, the battery approach proposes the incorporation of wind generators with battery energy storage (BES) system to provide WPPs with controllability [10,11]. Then, if BES is properly sized and operated, not only can the imbalance cost be reduced (or even eliminated), but WPPs can also take advantage of the price discrepancy opportunity in the spot market. This makes the idea very attractive and promising. However, the limits of the state-of-the-art studies in this approach are that they only address the arbitrage opportunity provided by BES, but completely ignore its cost (BES cost). This deficiency may lead to an abusive utilization of BES which dramatically decreases the battery lifetime.

Our work lies in the third approach which addresses the operation problem of BES installed in wind generation system. In this work, we provide a framework for optimally scheduling of BES according to the prediction of market prices and the probabilistic information of real-time generation. In order to address the limits of previous studies, the BES cost is included under the newly defined term: cost of lifetime losses (CLL). Thus, the objective of scheduling is not only maximizing the income from market, but maximizing the overall profit (*i.e.*, the income after subtracting the expense of BES). Another new

contribution of this work is to address the fluctuation of wind generation in real-time, which if not properly treated may break the physical constraints of BES: maximum rate of charge/discharge, minimum state of charge, *etc.* The optimal scheduling of BES obtained is our proposed charging/discharging scheme. It is noted that the bidding strategy in the spot market is out of the scope of this paper.

The remainder of this paper is organized as follows. Section II outlines the market scenario adopted in this paper that is a bit different from Nordpool. Section III analyses the state-of-the-art lifetime model of battery and formulates the cost of lifetime losses (CLL) as a function of operating conditions. Section IV provides the mathematical formulation of the optimal scheduling of BES. The formulation is then put into Dynamic Programming (DP) framework and solved by DP backward algorithm. Section V presents the application of the proposed charging/discharging scheme in study cases and the comparison of with and without BES cost consideration. Finally, Section VI summarizes the significant points and discussions.

## 2. Outline of Deregulated Market

The electric power industry is experiencing a major restructuring process which intends to put both generation and consumption sectors into market forces with the ultimate target of decreasing the market prices. The basis of this process is liberalizing the electric market, *i.e.*, deregulated market; through which operations of system users are decided. This section presents a variant of deregulated market which consists of two different submarkets: day-ahead market and real-time market.

### 2.1. Day-ahead Market

The day-ahead (DA) market is similar to the spot market of Nordpool [5]. In this market, producers and consumers submit bids which indicate the quantity of electricity and the corresponding prices they are willing to sell or purchase. The Market Operator (MO), based on the submitted bids, constructs the selling and purchasing curves; the intersection of these curves gives the market clearing price (MCP) (or spot price) and the accepted bids for each hour of the coming day.

The DA market is closed at noon and twelve hours before the physical transactions. The bidding strategy in the spot market is exclusively studied in [5–9], that is out of the scope of this paper. The DA market clearing prices is illustrated in Figure 1.

**Figure 1.** The principle of clearing price in DA market.

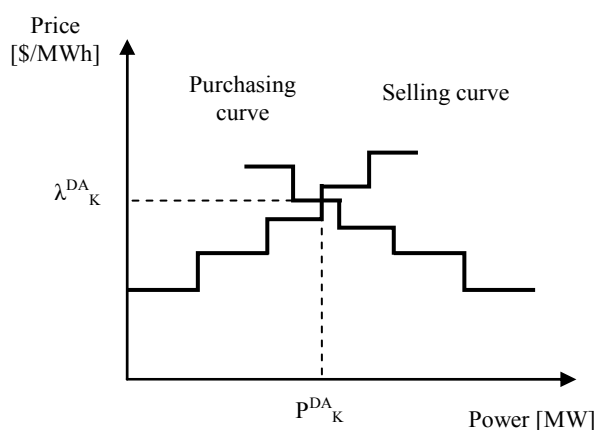

## 2.2. Real-Time Market

The real-time (RT) market is usually managed by Independent System Operation (ISO) to deal with power imbalance caused by the natural variation of loads (and nonconventional sources) in real-time operation. This power imbalance refers to the deviation from the value which has been bid in the DA market. In RT market, the technically qualified generators, e.g., gas-fired, can submit bids for fast increase and decrease of their power outputs. These bids are then arranged in price order (from cheapest to the most expensive one); by thus, ISO depends on the actual needs in the system to determine which generators to be selected. The most expensive/cheapest of up/down regulation bid being picked gives the regulation price (Figure 2).

**Figure 2.** Up/down regulation prices in real-time market.

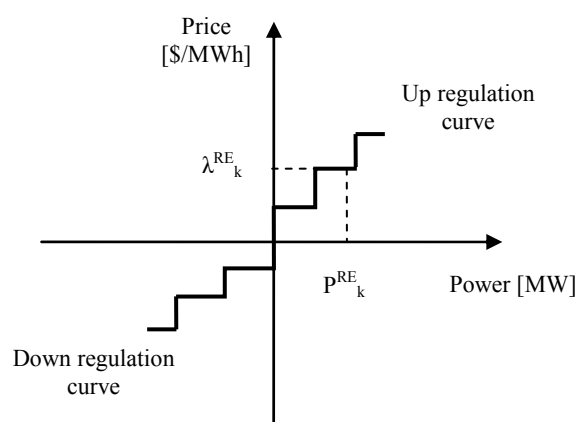

Up to this point, the regulation price is presented similarly to what described in [5]. However, the difference lies the time basis on which the regulation price is determined. In [5], the regulation price is set for an entire hour (the time basis of the spot market), corresponding to the most expensive upward regulation or the cheapest downward regulation bids being taken. In RT market, on the other hand, the regulation price is set every 5 minutes in accordance with the actual regulation needs. These prices are then posted in the end of each hour, *i.e.*, *ex-post* prices. The RT prices are determined with a 5 minutes time basis as follows:

$$\lambda_k^{RT} = \lambda_K^{DA} + \lambda_k^{RE} \quad (1)$$

## 2.3. Market Settlements

The settlement of DA market is straightforward based on the accepted bids and MCP. Likewise, regulation providers get paid or pay according to the RT prices and the amount of increase or decrease of their power output in real-time; however, the case of regulation consumers is a bit more complicated depending on the actual need of the overall system. If load with power deviation that helps to balance the overall system, *i.e.*, load is higher than the DA bid during the time when down-regulation is ordered (surplus of power in overall system) and *vice versa*, *i.e.*, lower during up-regulation is needed; then this load is not considered consuming regulation, he/she pays or gets paid according to the spot market. Only the load with deviation that causes imbalance in the overall system is considered as regulation consumer who needs to charge according to the RT prices.

### 3. Battery Energy Storage

Battery energy storage (BES) has long been a solution for improving the reliability and performance of power systems, particularly, it is considered as the key technology for integrating RES into the electric power network. Despite many advantages carried by BES, its application is very limited due to the lack of experience and tools for: (i) operational cost optimization, and (ii) assessing the benefits considering the market model [12]. Reviewing some emerging studies on the operating conditions, stress factors and lifetime models of battery in renewable application, this section aims to provide an evaluation of the cost associated with the actual operation of BES, named cost of lifetime losses (CLL).

#### 3.1. Battery Wear Cost and Lifetime Model

A BES system mainly consists of a battery bank, control and power conditioning system, and rest of the plant which provides protection for the entire system. Physically, the lifetime of battery bank is quite short compared to other components, thus its replacement cost has great impact on the economic planning (sizing) and operation of BES. In [13], the cost associated with an ampere-hour (Ah) charging and discharging (roundtrip) through battery is evaluated, named battery wear cost, as follows:

$$c^{bw} = \frac{C_{rep}}{N \cdot Q_{lifetime} \sqrt{\eta_{rt}}} \quad (2)$$

Generally, the lifetime of a battery bank is given by the manufacturer in terms of lifetime-throughput; that indicates the theoretical amount of Ah can be charged and discharged through the battery bank until the end-of-life is reached. This lifetime throughput is obtained by various test methods processing under certain conditions (*i.e.*, standard conditions). The matter of fact is that these test conditions are usually not achievable in practice, particularly, under in renewable application scenarios. Indeed, the operating conditions of BES in renewable energy systems are characterized by: (i) partial state of charge (SoC), (ii) incomplete or rare full charge state, and (iii) a wide range of ambient temperatures [14]. In [15], six important stress factors are defined which link the operating conditions to the lifetime of a battery bank, such as charge factor, Ah-throughput, time between full charge, time at low SoC, and temperature. It is worth noting that these stress factors can physically reduce the rate of one aging process and increase the rate of another. For instance, a high temperature will accelerate the rate of corrosion, but will decrease the rate of formation of hard, irreversible sulphation products (in a lead-acid battery). Therefore, quantifying the influence of stress factors on the lifetime of a whole battery bank needs a thorough understanding and analysis of the entire aging processes.

In order to evaluate the battery lifetime, three different approaches are presented in [16–18]. The first approach, called performance-based model, is based on the simulation of each aging process as a function of operating conditions and the change of performance values of the battery while the various aging processes take place. The battery is said to be at end-of-life if the performance values cross the thresholds. This method is very accurate, but may suffer from a huge computational burden. The second approach, called Ah-throughput model, is based on an assumption that once a predetermined

value of Ah-throughput has been exceeded, the battery is considered to have reached end-of-life. For taking the operating conditions into account, the weight factors are added and it is then called weighted Ah-throughput model. The third approach, called event-oriented model, is based on an assumption that the incremental loss of lifetime caused by different events is added up until a certain value is reached. Thus, in some sense, this approach shares a similar basis the weighted Ah-throughput model.

### 3.2. Cost of Lifetime Losses

In this paper, the weighted Ah-throughput model is adopted to evaluate the cost associated with lifetime losses according to the actual operating conditions. The model assumes that the impact of a given Ah-throughput in the lifetime of battery depends on the details of the operating conditions during the Ah throughputs. This means under standard conditions, battery can achieve the theoretical Ah-throughput; any deviation from the standard conditions will result in a virtual increase (or decrease) of the physical Ah-throughput. The impact of SoC on the lifetime of battery is modeled in [17]:

$$f_{SoC} = 1 + (c_{SoC,0} + c_{SoC,min} (1 - SoC_{min})) \times f_I(I, n) \Delta t_{SoC} \quad (3)$$

For simplicity, we only consider the impact of SoC, other factors such as current, acid stratification, *etc.* will be ignored. Then, (3) becomes:

$$f_{SoC} = 1 + c_{SoC,min} (1 - SoC_{min}) \quad (4)$$

Therefore, for each Ah-throughput at given conditions will result in virtual loss of lifetime which costs:

$$\begin{aligned} c_{ll} &= c^{bw} (f_{SoC} - 1) \\ &= c^{bw} c_{SoC,min} (1 - SoC_{min}) \end{aligned} \quad (5)$$

In other words, the cost of lifetime losses (CLL) represents the monetary loss due to the losses of lifetime for one Ah throughputs at certain conditions which deviate from the standard one. Roughly, (5) implies that it is more economical to operate BES at higher SoC. This is because low SoC physically cause mechanical stress on the active masses and increase size of sulfate crystal (lead-acid battery) [17].

## 4. Proposed Charging/Discharging Scheme of Battery Energy Storage

In such market environment presented in Section 2, the opportunity is that WPP can be rewarded by properly operating his/her BES in response to the variation of market prices which helps to balance the overall system. This section provides a framework for determining the optimal charging/discharging operation of BES in the next day according to the prediction of RT prices and the probabilistic wind generation information. Mathematically, the formulation is to maximize the overall profit (*i.e.*, income after subtracting the BES cost) that WPP might obtain from the RT market; this means the BES should store (charge) electricity during the low price time and re-sell (discharge) when the price is high. The optimal charging/discharging therefore will be determined in every 5 minutes (the time basis of RT market). The formulation of this problem is restricted to the following assumptions:

1. The WPP is price-taker, *i.e.*, he/she has no capability to alter the MCP.

2. An appropriate prediction tool is available to forecast the next day generation and estimate the probability density function of real-time (5 minutes) variation.
3. Bidding strategy in the DA (spot) market is out of the scope of this paper. Without losing generality, it is assumed the mean values are bid.

4.1. Problem Formulation

The outline of WGS with BES is sketched in Figure 3. It is worth noting that the BES in this case performs two important tasks:

Figure 3. Outline of WGS with BES.

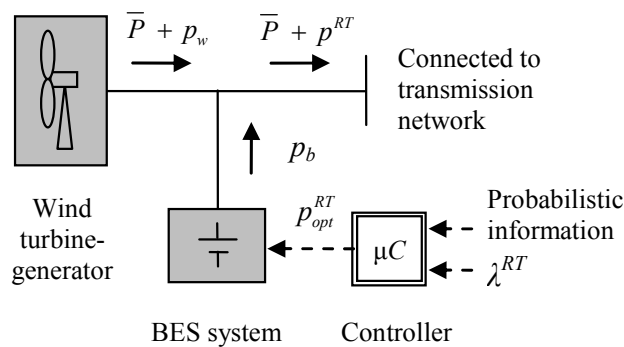

1. Absorbing the real-time variation of power output resulted from the intermittence of wind speed.
2. Dispatching in accordance to the RT market prices for profits.

The profit that WPP receives in period k after subtracting the BES cost can be evaluated as follows:

$$\Pi [k] = p^{RT} [k] \lambda_k^{RT} - c^{bw} c_{SoC, \min} (1 - SoC_{\min} [k]) Ah [k] \tag{6}$$

In (6) the first term represents the revenue from the RT market, while the second term represents the BES cost. The BES cost is calculated as product of the cost of lifetime losses (CLL) and the amount of Ah-throughput during the period k. The actual charge/discharge of BES is related to the real-time dispatch and uncertainty (i.e., the deviation from prediction) as follows:

$$p^{RT} [k] = p_b [k] + p_w [k] \tag{7}$$

The objective function is to maximize the overall profits in a day that WPP can obtain considering the uncertainty of wind generation and the cost of BES:

$$\max_{p^{RT} [k], p_w [k]} E \left\{ \sum_k p^{RT} [k] \lambda_k^{RT} - c^{bw} c_{SoC, \min} (1 - SoC_{\min} [k]) Ah [k] \right\} \tag{8}$$

The problem solution subjects to the following constraints of BES:

1. State of charge transition:

$$SoC_{k+1} = \begin{cases} SoC_k - \eta_c p_b [k] \Delta t & \text{if charging} \\ SoC_k - \frac{1}{\eta_d} p_b [k] \Delta t & \text{if discharging} \end{cases} \tag{9}$$



2. State of charge limits:

$$SoC_{max} \geq SoC_k \geq SoC_{min} \tag{10}$$

3. Rate of charge/discharge limits:

$$\begin{aligned} RoC_{max} &\geq -p_b \geq RoC_{min} && \text{if charging} \\ RoD_{max} &\geq p_b \geq RoD_{min} && \text{if discharging} \end{aligned} \tag{11}$$

4.2. Dynamic Programming Framework

The formulated problem can be solved by the Dynamic Programming (DP) method. The state of BES (SoC) is discretized to fit the DP framework for discrete finite state problems [19]. Then, the DP backward algorithm is applied to solve for the optimal charging/discharging of BES in the next day. This is our proposed scheme. The DP framework is displayed in Figure 4.

Figure 4. DP framework for discrete finite state problem.

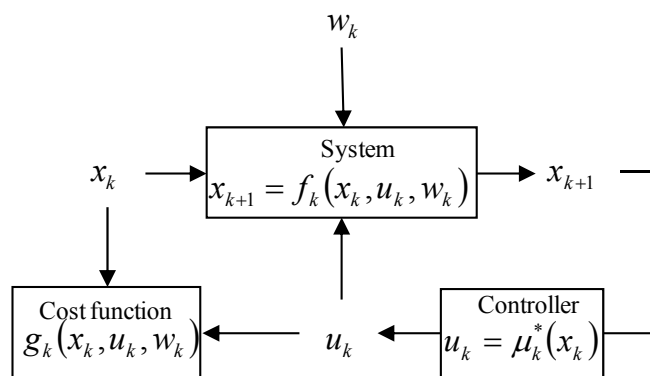

In DP framework, let us define:

1. State variation  $x_k$  be the SoC of BES at the end of period  $k$ .
2. Control variable  $u_k$  be the real-time dispatch of WPP during period  $k$ .
3. Random variable  $w_k$  be the uncertainty of wind generation in period  $k$ .

The state transition function of DP framework can be rewritten from (9) as:

$$x_{k+1} = \begin{cases} x_k - \eta_c (u_k - w_k) \Delta t & \text{if } u_k - w_k \leq 0 \\ x_k - \frac{1}{\eta_d} (u_k - w_k) \Delta t & \text{if } u_k - w_k > 0 \end{cases} \tag{12}$$

The cost function in DP framework is defined as minus of the overall profit in (6):

$$g_k(x_k, u_k, w_k) = -u_k \lambda_k^{RT} + c^{bw} c_{SoC, min} (1 - x_k^{min}) Ah_k \tag{13}$$

Then, the cost-to-go function is calculated as:

$$\begin{aligned}
 J_N(x_N) &= 0 \\
 J_k(x_k) &= \min_{u_k, w_k} E \{ g_k(x_k, u_k, w_k) + J_{k+1}(x_{k+1}) \}, \\
 & \quad k = 1, 2, \dots, N-1
 \end{aligned}
 \tag{14}$$

with the time basis ( $\Delta t$ ) of 5 minutes in RT market,  $N = 24 \times 12 = 288$  periods in a day. The problem constraints remain as (10) and (11). The DP backward algorithm results in the optimal policy in the form:  $\pi^* = \{\mu_0^*, \mu_1^*, \dots, \mu_{N-1}^*\}$ ; from which, once the current state is known, the optimal decision (control) can be determined as:  $u_k^* = \mu_k^*(x_k)$  [19].

### 5. Case Study

In this section, the proposed charging/discharging scheme of a BES is applied to a study case. A wind generation system owned by a WPP is depicted in Figure 3. The market price data was found in the PJM website [20]. The parameters of BES were found on the Surrrette Battery Company website [21]. It is assumed that 4KS25P battery bank is employed in the BES which has  $C_{rep} = \$1,000/\text{unit}$ ;  $Q_{lifetime} = 10,494 \text{ kWh}$ ;  $\eta_{rt} = 0.8$ . The battery wear cost can be evaluated by (2):  $c^{bw} = \$106.5/\text{MWh}$ . Other parameters of BES are:  $SoC_{max} = 10 \text{ MWh}$ ;  $SoC_{min} = 4 \text{ MWh}$ ;  $RoC_{max} = 1,000 \text{ kW}$ ;  $RoD_{max} = 1,000 \text{ kW}$ ; and  $c_{SoC, min} = 0.15$ . The probabilistic information of wind generation is given in term of prediction percentages as follows:  $p_w = \pm 10\%$  with pdf = 0.05;  $p_w = \pm 5\%$  with pdf = 0.2; and  $p_w = 0\%$  with pdf = 0.5. It is assumed that the BES must be at low SoC (5 MWh) at midnight (12:00 AM) to take advantages of the low prices and the increased availability of the wind resource at nighttime. Figure 5(a) displays the DA (spot) price and the RT (real-time) price. It is shown that in some periods the RT price is higher than the DA price but at other times, it is lower.

**Figure 5. (a)** The day-ahead (spot) prices and real-time prices; **(b)** The hourly prediction and actual generation of WGS.

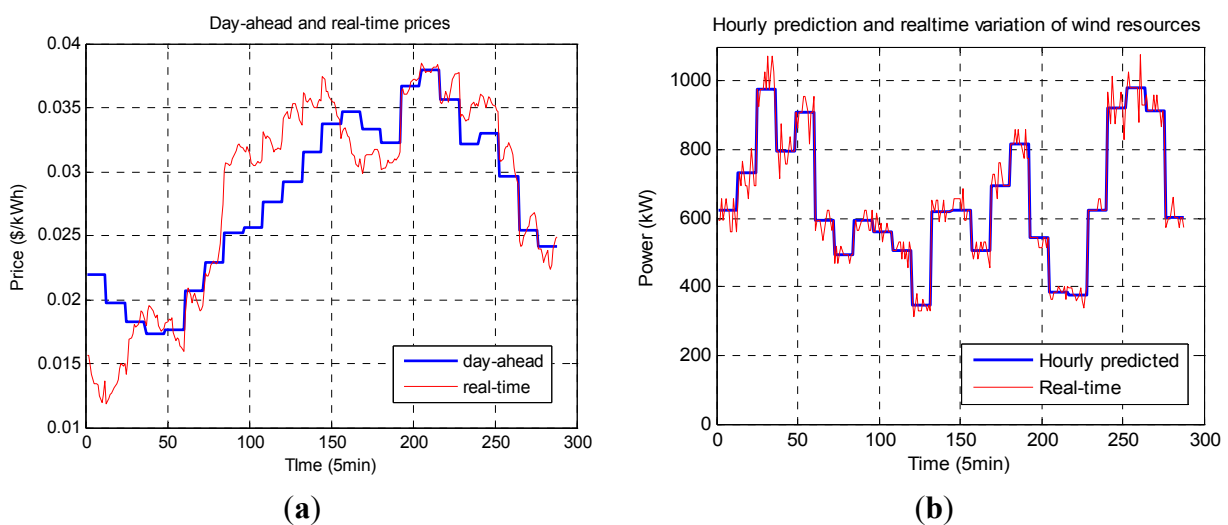

This is because, when the overall system lacks of power (*i.e.*, the demand is higher than the supply), ISO will order more generation from up-regulation bids; this results in a positive regulation price (Figure 2) and then, the RT price is higher than the DA price. The situation is the inverse in the case of a surplus of power in the overall system. Figure 5(b) shows the hourly prediction of wind generation

and its real-time variation. It is assumed that there is no bias in the prediction and these amounts is bided in the day-ahead market.

### 5.1. Case 1: Without BES Cost Consideration

In case 1, the optimal charging/discharging of BES is determined without consideration of BES cost. The objective in this case is to maximize the profit that WPP can obtain from the RT market. The term of BES cost is rejected from (8). The problem constraints remain the same in (10) and (11). The problem is solved by DP backward algorithm and the simulation is run in MATLAB program. The result of simulation shows the optimal dispatch ( $p^{RT}[k]$ ) and state of charge ( $SoC[k]$ ) of BES in Figures 6 (a,b), respectively.

**Figure 6.** (a) The optimal dispatch of WPP; (b) The SoC of BES in case 1.

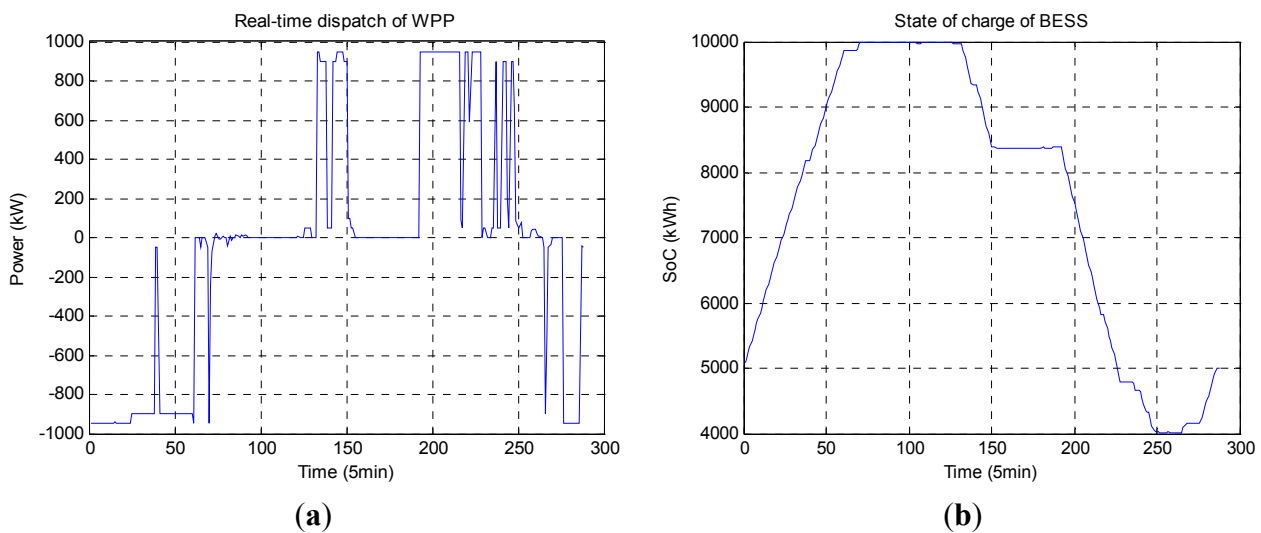

### 5.2. Case 2: With BES Cost Consideration

In case 2, the BES cost is considered. Then, the optimal charging/discharging of BES is to maximize the overall profit (*i.e.*, the income after subtracting the BES cost) as in (8). This results in the optimal dispatch ( $p^{RT}[k]$ ), state of charge ( $SoC[k]$ ) of BES in Figures 7(a,b), respectively.

The charging/discharging of BES in both case shows that the electricity is stored (charged) when the RT price is low and re-sold (discharged) when the RT price is high. In more detail, in the first six hours, the RT price is low, the WPP attempts to charge as much as possible to BES, but smaller than the maximum rate of charge to avoid over limits caused by the uncertainty of resources. The BES remains full of charge from 7:00 to 11:00 and waiting for the high price time later [Figure 6(b) and Figure 7(b)].

In the periods from 11:00 to 12:00; and from 16:00 to 20:00, the RT price is high (at peak), the WPP starts discharging BES to make a profit [Figure 6(a) and Figure 7(a)]. The difference between the two cases lies on the last periods (from 21:00 to 24:00). In case 1, without consideration of BES cost, the WPP tends to discharge BES exclusively until the  $SoC_{min-}$  is reached; and later then, charge to SoC of 5 MWh (*i.e.*, ending constraint). In case 2, with consideration of BES cost, the BES remains its SoC of 5 MWh because in these periods, the discrepancy in RT prices is not enough to cover the BES cost.

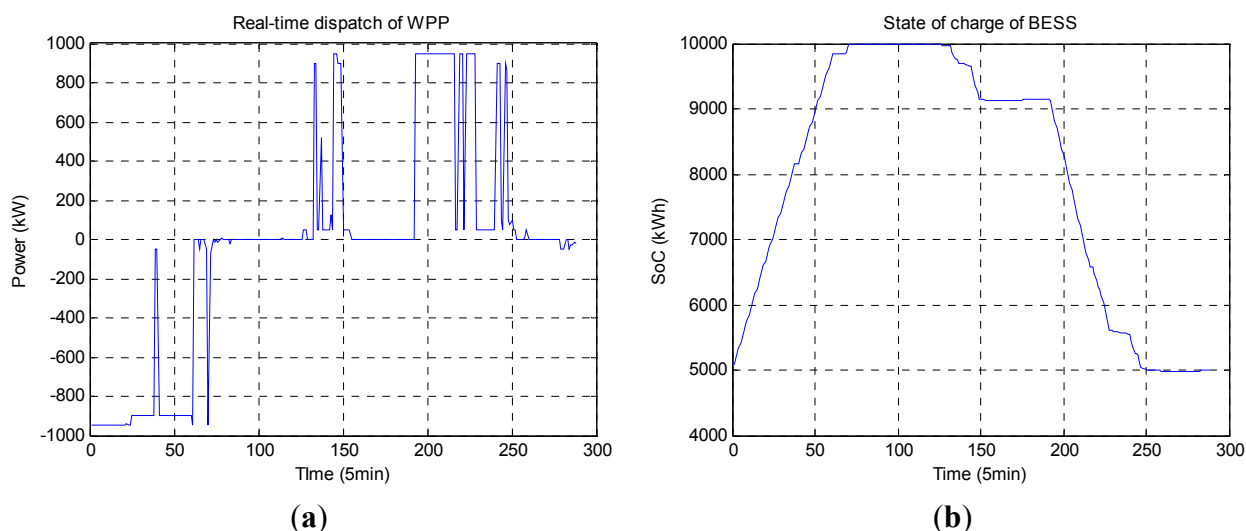
**Figure 7.** (a) The optimal dispatch of WPP; (b) The SoC of BES in case 2.

The profit from the RT market, BES cost and the overall profit in two cases are presented in Table 1. It is shown that the case 1 aims to maximize only the profit from the RT market in a day (\$80.963); however, this operation lead to the abusive utilization of BES which results in high BES cost (\$35.113). Then, the overall profit WPP obtains is \$48.850. Case 2, on the other hand, even though the profit obtained from RT market is lower than case 1 (\$74.839), the BES is significantly reduced (\$24.859). Thus, the overall profit for WPP is higher (\$49.980). The saving of our proposed scheme (case 2) in these study cases is about 9%.

**Table 1.** Comparison of the economic results between two cases.

Study cases	Profit from RT market	BES cost	Overall profit
Case 1	80.963	35.113	45.850
Case 2	74.839	24.859	49.980

It is worth noting that the value of cost-to-go function resulted from DP backward algorithm is not exactly the overall profit in case 1 and 2, instead this (cost-to-go function) is the expected value of the profit according to different scenarios of wind resource uncertainty. The results of case 1 and 2, on the other hand, are obtained from the actual operation when the scenarios are cleared.

## 6. Conclusions

This paper provides a framework for determining the optimal charging/discharging of a BES which provides the maximum overall profit for a WPP. In addition, the BES expense is considered under the newly defined term: cost of lifetime losses. The problem formulation is then put into a DP framework where the DP backward algorithm can be applied. The solution is the optimal policy by which, once the current state is known (in real-time operation), the optimal charging/discharging of a BES can be determined. This is our proposed charging/discharging scheme. In the case study, the optimal operation of the BES in two different cases is examined. In case 1, the BES cost is not considered while in case 2, the proposed scheme is adopted. The increase in the overall profit of case 2 compared to case 1 has shown the effectiveness of our proposed scheme.

This work is restricted to considering the entire expense of BES. We believe that with the expensiveness of the battery technologies nowadays, it is impossible to create profit from the variation of electricity prices. Instead, the analysis of this paper provides some insights for the optimal scheduling of an existing BES and possibly with some modifications, other energy storage technologies, e.g., a hydro-pumped power plant.

### Acknowledgments

This work was supported by the Ministry of Knowledge Economy (KME) as a part of its research on Electric Power System (2011T100100152).

### References

1. Munksgaard, J.; Morthorst, P.E. Wind Power in the Danish Liberalised Power Market—Policy Measures, Price Impact and Investor incentives. *Energy Policy* **2008**, *36*, 3940–3947.
2. Morthorst, P.E. Wind power and the condition at a liberalized power market. *Wind Energy* **2003**, *6*, 297–308.
3. Holttinen, H. Optimal electricity market for wind power. *Energy Policy* **2004**, *33*, 2052–2063.
4. Verhaegen, K.; Meeus, L.; Belmans, R. Development of balancing in the internal electricity market in Europe. In *Proceedings of the European Wind Energy Conference & Exhibition*, Athens, Greece, 27 February–2 March 2006.
5. Matevosyan, J.; Soder, L. Minimization of imbalance cost trading wind power on the short-term power market. *IEEE Trans. Power Syst.* **2006**, *21*, 1396–1404.
6. Pinson, P.; Chevallier, C.; Kariniotakis, G.N.; Trading wind generation from short-term probabilistic forecasts of wind power. *IEEE Trans. Power Syst.* **2007**, *22*, 1148–1156.
7. Bathurst, G.N.; Weatherill, J.; Strbac, G. Trading wind generation in short-term energy markets. *IEEE Trans. Power Syst.* **2002**, *17*, 782–789.
8. Bouffard, F.; Galiana, F.D. Stochastic security for operation planning with significant wind power generation. *IEEE Trans. Power Syst.* **2007**, *23*, 306–316.
9. Fabbri, A.; Roman, T.G.S.; Abbad, J.R.; Mendez, V.H. Assessment of the cost associated with wind generation prediction errors in a liberalized electricity market. *IEEE Trans. Power Syst.* **2005**, *20*, 1440–1446.
10. Bathurst, G.N.; Strbac, G. Value of combining energy storage and wind in short-term energy and balancing markets. *Electr. Power Syst.* **2003**, *67*, 1–8.
11. Korpaas, M.; Holen, A.T.; Hildrum, R. Operation and sizing storage for wind power plants in a market system. *Electr. Power Energy Syst.* **2003**, *25*, 599–606.
12. Divya, K.C.; Østergaard, J. Battery energy storage technologies for power system—an overview. *Electr. Power Syst. Res.* **2008**, *79*, 511–520.
13. Energy Modeling Software for Hybrid Renewable Energy System. HOMER Energy: Boulder, CO, USA. Available online: <http://www.homerenergy.com/download.html> (accessed on 1 August 2012).

14. Svoboda, V.; Wenzl, H.; Kaiserc, R.; Jossenb, A.; Baring-Goulidd, I.; Manwelle, J.; Lundsagerf, P.; Bindnerf, H.; Croninf, T.; Nørgårdf, P.; *et al.* Operating conditions of batteries in off-grid renewable energy systems. *Sol. Energy* **2007**, *81*, 1409–1425.
15. Kaiser, R. Optimized battery energy-management system to improve storage lifetime in renewable energy system. *J. Power Sources* **2006**, *168*, 58–65.
16. Wenzl, H.; Gould, I.B.; Kaiser, R.; Liaw, B.Y.; Lundsager, P.; Manwell, J.; Ruddell, A.; Svoboda, V. Lifetime prediction of batteries for selecting the technically most suitable and cost effective battery. *J. Power Sources* **2004**, *144*, 373–384.
17. Schiffer, J.; Sauer, D.U.; Bindner, H. Cronin, T.; Lundsager, P.; Kaiser, R. Model prediction for ranking lead-acid batteries according to expected lifetime in renewable energy systems and autonomous power-supply systems. *J. Power Sources* **2006**, *168*, 66–78.
18. Sauer, D.U.; Wenzl, H. Comparison of different approaches for lifetime prediction of electrochemical systems—using lead-acid batteries as example. *J. Power Sources* **2007**, *176*, 534–546.
19. Bertsekas, D.P. *Dynamic Programming and Optimal Control*; Athena Scientific: Belmont, MA, USA, 1995.
20. PJM Electric Market. Available online: <http://www.pjm.com> (accessed on 1 August 2012).
21. Surrrette Battery Company Limited. Available online: <http://www.surrrette.com> (accessed on 1 August 2012).

© 2012 by the authors; licensee MDPI, Basel, Switzerland. This article is an open access article distributed under the terms and conditions of the Creative Commons Attribution license (<http://creativecommons.org/licenses/by/3.0/>).